

CORDLESS BLIND RIVET NUT & BOLT BATTERY TOOL WITH BRUSHLESS MOTOR

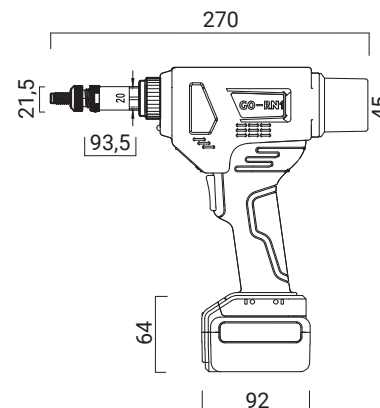

Arbeitsbereich / Capacity / Utilisation
M3 - M8
alle Materialien
all materials

CE conformity
Equipment safety according
EU Directive No. 2006/42/EG

Gewicht inklusive Akku	Weight including battery	Poids avec batterie	1,5 kg
L x B x H	L x B x H	L x B x H	270 x 55 x 260 mm
Material	Material	Matériau	PE
Hubeinstellung von/ bis	Stroke adjustable from/ up to	Course ajustable de	0,2 - 6,0 mm
Zugkraft	Traction power	Force de traction	18.000 N
Mundstückaufnahme	Nose piece adapter	Positionneur des embouts	ø 16,0 mm
Code	Code	Code	22770 30010

Ausrüstung / Equipment / Équipement

Dorne & Hülsen	Mandrel & Anvil	Mandrins & Nez de pose	M3, M4, M5, M6, M8
Umrüstsätze für Blindnietsschrauben (GO-BOLT) M5 - M8 separat lieferbar	Conversion kit for blind rivet bolts (GO-BOLT) M5 - M8 separate available	Set d'adaptateurs pour goujons (GO-BOLT) M5 - M8 livrables séparément	
Schnellwechselakku	Quick-change battery	Accumulateur changeable rapidement	2x Li-Ion 18 V / 2,0 Ah / 36 Wh
Ladegerät	Charger	Chargeur	18 V Li-Ion
ABS Koffer	ABS case	Coffret ABS	38 x 30 x 8 cm

Deform-Nut 18V Battery Tool Matching Blind Rivet Nuts:



Specialinsert
Deform-Nut
Specialty Rivet Nuts For Sheet Metal, Plastics And Composites

- Available in different sizes and materials
- Specialized versions such as high torque, self-locking, and stainless steel
- Fast, strong and versatile

Specialinsert
Cross-Nut
Deformation Threaded Insert

- Superior pullout resistance in soft materials
- Available in 10-24, 1/4-20, 3/8-16 and metric sizes
- Aluminum, stainless steel or zinc-coated steel
- Wide grip range

CORDLESS BLIND RIVET NUT & BOLT BATTERY TOOL WITH BRUSHLESS MOTOR

chemical-concepts.com
800.220.1966
410 Pike Road • Huntingdon Valley, PA 19006



DELIVERED WITH:



Specialinsert

Deform-Nut

Specialty Rivet Nuts For Sheet Metal, Plastics And Composites

- Available in different sizes and materials
- Specialized versions such as high torque, self-locking, and stainless steel
- Fast, strong and versatile



Specialinsert

Cross-Nut

Deformation Threaded Insert

- Superior pullout resistance in soft materials
- Available in 10-24, 1/4-20, 3/8-16 and metric sizes
- Aluminum, stainless steel or zinc-coated steel
- Wide grip range